

KOHOUT KULOVÝ S PLOVOUCÍ KOULÍ
KOHOUT KULOVÝ S PEVNOU KOULÍ
 Teplota max. -40°C/ 200°C

TYP K81 FLOATING
TYP K82 TRUNNION
CLASS 150
DN 1/2" – 32"

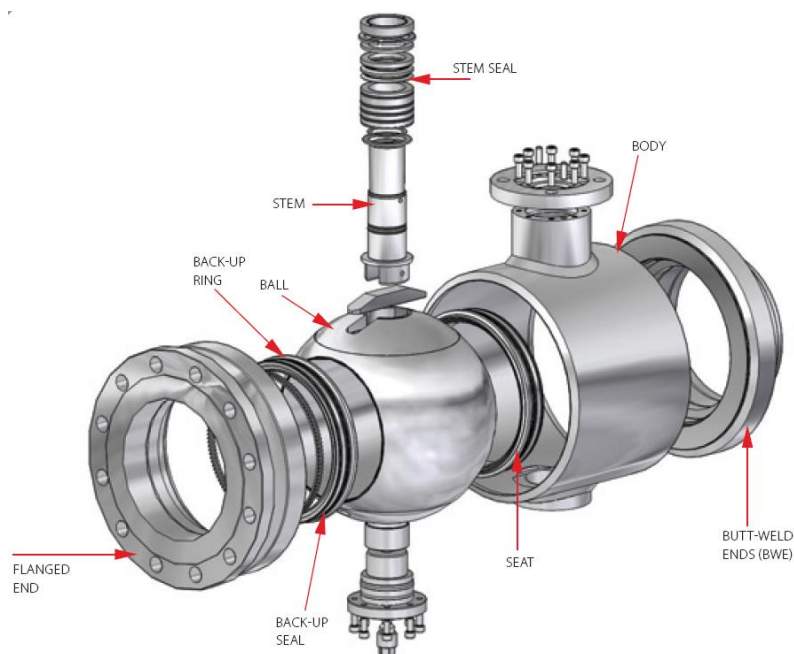

Přírubový konec

Záložní těsnění

Sedlo

Přivařovací konec (na tupo)

Těsnění ovládacího čepu

Těleso

Ovládací čep

Opěrný kroužek

Koule

MATERIÁLY / MATERIALS

DN	Těleso Body	Přírubový konec Flanged end	Přivařovací konec Butt-weld end (BWE)	Koule Ball	Ovládací čep Stem	Opěrný kroužek Back-up ring	Sedlo Seat	Záložní těsnění Back-up seal	Těsnění ovl. čepu Stem seal
1/2"	P355NH; P355NL1; S355J2; S355J2H	P355NH; P355NL1; S355J2	P355NH; P355NL1; S355J2; S355J2H	X5CrNi18-10 (AISI 304)	X20Cr13 (AISI 420)	CS+NiCr SS CS+EN	PTFE; PTFE+C	HNBR; EPDM; FKM; Grafit/ Graphite	HNBR; EPDM; FKM; Grafit/ Graphite; PTFE
3/4"									
1"									
1 1/4"									
1 1/2"									
2"									
2 1/2"									
3"	P355NH; P355NL1; S355J2; S355J2H	P355NH; P355QH	P355NH; P355NL1; S355J2; S355J2H	S355J2+NiCr A350LF2+EN					
4"									
6"									
8"									
10"									
12"									
14"									
16"									
20"									
24"									
28"									
32"									

Klasifikace produktů Classification of the products	Typ Type	Rozsah Scope
Kulový kohout z uhlíkové oceli, plný průtok, Class 150 Ball valve from carbon steel, full bore, Class 150	AH-2c-MK; AH-2c-MP; AH-2c-MG	DN (NPS) 1/2"-1"
	AH-2c; AH-2cp; AH-2cg	DN (NPS) 1 1/4"-3"
	AH-11c; AH-12c	DN (NPS) 4"-6"
	AH-14c; AH-15c	DN (NPS) 8"-32"

Rozsah teplot (°C) Temperature range (°C)
t = -29°C ÷ +100°C
t = -40°C ÷ +100°C
t = -20°C ÷ +150°C
t = -10°C ÷ +200°C

ROZMĚRY (mm) / DIMENSIONS (mm)

NPS	d	F	t	DBB	IS	L			B	I	D1	T
						FxF	WxW	GxG				
1/2"	15	X	-	-	-	108,0	140,0	100,0	37,0	21,0	21,3	3,2
3/4"	20	X	-	-	-	117,0	152,0	110,0	40,0	24,0	26,9	3,6
1"	25	X	-	-	-	127,0	165,0	135,0	48,0	30,0	35,0	5,0
1 1/4"	32	X	-	-	-	140,0	178,0	150,0	83,0	35,0	42,4	3,6
1 1/2"	40	X	-	-	-	165,0	190,0	160,0	87,0	40,0	48,3	3,6
2"	50	X	X	OPTION	-	178,0	216,0	160,0	95,0	48,0	60,3	4,0
2 1/2"	64	X	-	-	-	190,0	241,0	210,0	122,0	59,0	76,1	5,0
3"	78	X	X	OPTION	-	203,0	283,0	-	130,0	71,0	88,9	5,6
4"	101	X	X	OPTION	OPTION	229,0	305,0	-	173,0	90,0	114,3	6,0
6"	152	X	X	OPTION	OPTION	394,0	457,0	-	253,0	137,0	168,3	7,1
8"	202	-	X	X	OPTION	457,0	521,0	-	252,0	203,0	219,1	8,8
10"	253	-	X	X	OPTION	533,0	599,0	-	315,0	248,0	273,0	10,0
12"	304	-	X	X	OPTION	610,0	635,0	-	355,0	288,0	323,9	10,0
14"	336	-	X	X	OPTION	686,0	762,0	-	378,0	311,0	355,6	11,0
16"	386	-	X	X	X	762,0	838,0	-	433,0	480,0	406,4	12,5
20"	488	-	X	X	X	914,0	991,0	-	561,0	570,0	508,0	12,5
24"	588	-	X	X	X	1067,0	1143,0	-	654,0	682,0	610,0	12,5
28"	684	-	X	X	X	1245,0	1346,0	-	806,0	790,0	711,0	14,2
32"	780	-	X	X	X	1372,0	1524,0	-	890,0	900,0	813,0	16,0

OPTION = Volitelně

HMOTNOST (kg) / WEIGHT (kg)

NPS	FxF	WxW	GxG
	CL 150	CL 150	CL 150
1/2"	2,0	1,2	1,2
3/4"	2,7	1,6	1,5
1"	4,4	3,0	3,1
1 1/4"	4,5	2,7	2,8
1 1/2"	6,5	3,5	3,9
2"	9,1	4,8	5,1
2 1/2"	14,9	8,4	9,4
3"	18,9	13,5	-
4"	35,0	28,0	-
	46,0	30,0	-
6"	97,0	79,0	-
	99,0	81,0	-
8"	148,0	130,0	-
10"	273,0	240,0	-
12"	467,0	421,0	-
14"	594,0	557,0	-
16"	970,0	900,0	-
20"	1700,0	1610,0	-
24"	2740,0	2570,0	-
28"	4360,0	4126,0	-
32"	6296,0	6145,0	-

DALŠÍ POZNÁMKY / ADDITIONAL COMMENTS

Rozměry přírub podle EN 1759-1; ASME B 16.5.
 Flange dimension acc. to EN 1759-1; ASME B 16.5.
 Standardní těsnící plochy přírub: B podle EN 1079-1; RF podle ASME B 16.5.
 Flanges standard sealing surface: B acc.to EN 1079-1; RF acc.to ASME B 16.5.
 Konce pro přivaření na tupo podle EN 12627.
 Butt-weld ends acc. to EN 12627.
 Rozměry D1 a T po vzájemné dohodě.
 Dimensions D1 and T to agree.
 Závitové konce podle ISO 228-1 nebo ASME B1.20.1.
 Threaded end acc. to ISO 228-1 or ASME B1.20.1.

X = Je k dispozici = Available
 F = Plovoucí koule = Floating ball
 t = Čepově uložená koule = Trunnion mounted ball
 DBB = Double block and bleed
 IS = Vstříkovací systém = Injection system
 FxF = Přírubové konce = Flanged ends
 WxW = Přivařovací konce = Butt-weld ends
 GxG = Závitové konce = Threaded ends

